

HCD Series

# Desiccant Dehumidifier



## Product Description

**Process Air:** Flow rates of 2250-9000 scfm. Nominal moisture removal: 120 lbs/hr at 75°F, 50% RH at 4500 scfm. Delivered air moisture levels of -55°F dewpoint and lower are attainable.

**Contact Air Seals:** Separate process and reactivation air at pressures up to 8" W.G. with 5 years life expectancy.

**Process & Reactivation Fans:** Centrifugal, direct drive with totally enclosed fan cooled motors.

**Electrical Controls:** Continuous automatic operation including motor starters, overload protective devices, microprocessor with indicating lights and fault circuits. All wiring to NEC codes.

**Drive System:** Simple, self-tensioning drive belt arrangement, few moving parts.

**Reactivation Utility:** Electric with solid state proportioning control, steam with proportional air volume control or gas (direct/indirect) with modulating gas valve.

**Dehumidifier Housing:** Process and reactivation air flow insulation. Durable air-dry polyurethane paint. All welded aluminum cabinet.

## PRODUCT INFORMATION

# HCD-4500

## MODULAR DEHUMIDIFIER UNITS WITH OPTIONS

### Advantages:

- Weather-tight construction for indoor or outdoor use
- Low profile cassette design
- Quick access for easy maintenance
- Easy duct connections
- Modulating electric, gas or steam reactivation
- Multiple blower orientations
- Built-in bypass option
- Add-on post-/pre-air treatment options

## Desiccant Rotors

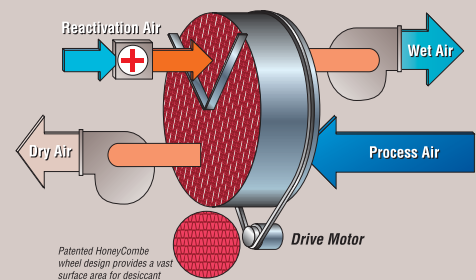

In the 1950's Munters invented modern industrial dehumidification when it introduced the self-regenerating desiccant rotor, the heart of the dehumidifier.

Today, Munters offers rotors with five desiccant formulations and is the acknowledged expert in the integration of rotors into dehumidification systems and air handlers.



The Humidity Expert

**MODEL HCD-4500 – EA (ELECTRIC)**

General arrangement drawings for other electric, steam or gas reactivation units available from your local representative or factory. Below drawing for illustrative purposes, not for construction. Consult factory for certified drawings.

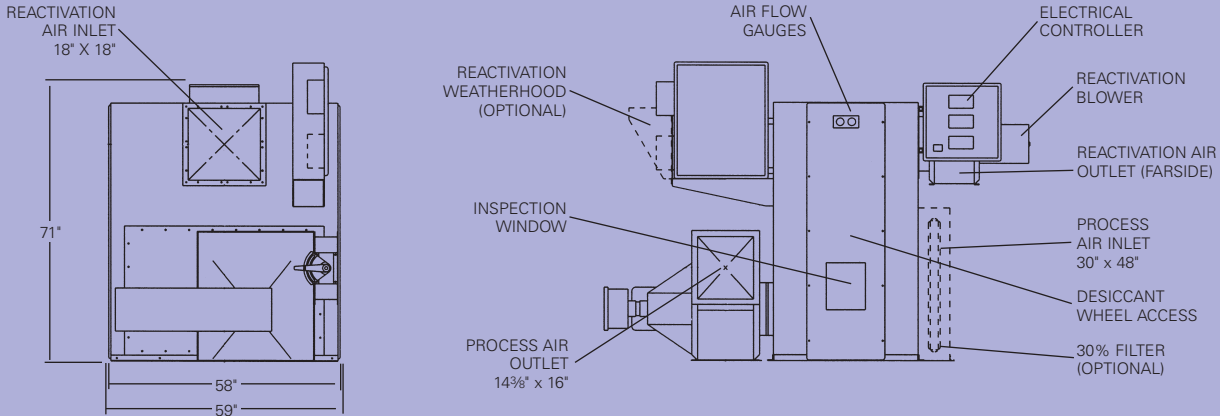

**DIMENSIONS TABLE FOR EA (ELECTRIC), SA (STEAM), GA (INDIRECT GAS FIRED) AND DGA (DIRECT GAS FIRED) REACTIVATION**

Model	Max Length (in.)	Max Width (in.)	Max Height (in.)	Max Weight (lbs.)	Typical/External Static Pressures (in. W.G.)	
					Process	React
HCD-4500 EA	110	60	77	1550	2.5	2.3
HCD-4500 SA	110	60	71	1580	2.5	2.7
HCD-4500 GA	146	66	85 indoor 98 outdoor	2050	2.5	2.4
HCD-4500 DGA	127	66	71	2050	2.5	2.3

**Suggested Specification Guide:**

Dehumidifier shall be of a type proven in satisfactory operation for a minimum of ten years. Dehumidifier shall be of the non-cycling sorption type with a single desiccant rotary structure. The casing will be fabricated as a unitized body with welded aluminum construction for maximum strength and durability. Suitable access panels on both sides of the unit shall allow access for inspection or servicing without disconnecting ducting or electrical wiring. Airflow balancing dampers to be furnished. The dehumidifier shall be designed for continuous operation.

The rotary structure shall be a monolithic fabricated extended surface composite consisting of inert silicates reinforced with uniform diameter glass fibers for maximum strength. The fabricated structure shall be smooth and continuous in the direction of airflow without interruptions or sandwich layers which restrict airflow or create a leakage path at joining surfaces. Desiccant shall not channel, cake or fracture due to repeated temperature and moisture cycling. The materials of construction shall be non-toxic and NFPA 255-ASTM E84 compliant.

The desiccant wheel shall be a single piece for fast removal and simple handling. The desiccant wheel shall be supported by four rollers at the base of the unit so the wheel can be easily removed for maintenance by lifting it

over the rollers using the drive belt. Center-axle support or any arrangement which requires disassembly of the support structure for wheel removal shall not be acceptable.

Design shall be modular in approach to readily allow connection to accessories such as face & bypass, pre- or post-cool modules.

Electrical components shall be UL/CSA recognized and wiring methods in accordance with the latest edition of the National Electric Code. Power supply shall be \_\_\_Volts/3 Phase/\_\_\_Hertz.

Full face contact pressure seals shall be provided to separate the process and reactivation airstreams and eliminate detrimental leakage of air or moisture with static pressure differentials of up to 8" of water gauge.

Dehumidifier shall be factory assembled, fully automatic, complete with HoneyCombe desiccant wheel, reactivation heaters, reactivation energy control system, roughing filters, motors, fans, non-ratcheting desiccant drive unit, automatic controller and all components' auxiliaries. Dehumidifier shall be functionally tested at the manufacturer's factory and shipped complete with all components necessary to maintain normal operation.

\*Continual engineering and research for product improvement may result in design and specification changes. Consult factory for certified technical data.

**Technical Specifications\***

Utilities: 208, 230, 460 or 575 Volts

Reactivation Heaters:

EA-Electric: 208-575 volts.

SA-Steam: 10-150 psig.

GA/DGA-Gas: Natural or propane 4.5 to 14" W.G. pressure.

Max Reactivation Air Volume: 1300 scfm

Reactivation Filter: Permanent and washable

Electric Controller: NEMA 4

Installation: Indoors or outdoors

Options: On/Off or modulating humidity control, internal or external bypass, skirts, weatherhoods, pre- and post-air treatment modules can include filtration, cooling and heating.

Typical Energy Consumption:

MODEL EA VOLTAGE	HEATER KW	UNIT AMPS
208	96	285
230	96	260
460	96	139
575	96	115

Munters Corporation  
 Dehumidification Division - Industrial  
 79 Monroe Street  
 Amesbury, MA 01913  
 Tel: (978) 241-1100 or (800) 843-5360  
 Fax: (978) 241-1214  
 www.munters.us  
 M162011 Rev.5 10/07  
 ©2007 Munters Corporation  
 HoneyCombe® is a registered trade name of Munters Corporation

